

World leaders in dehumidification.

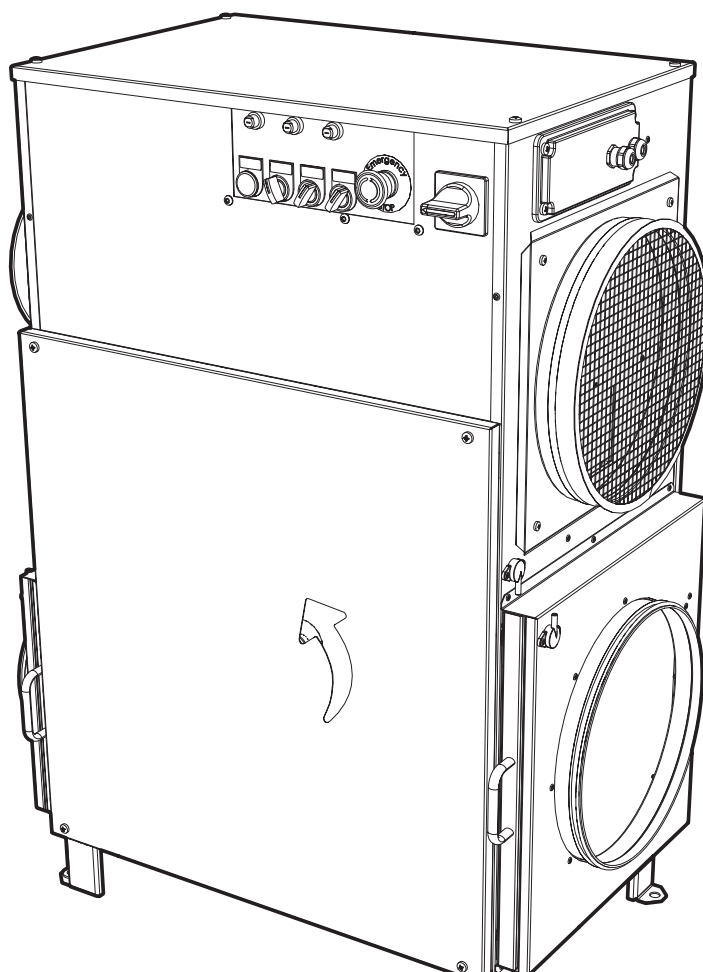

USER'S MANUAL

Document version: EN.052 24.01
Product: RL-60/60L



CE Desiccant dehumidifier

Product supplied may differ from that illustrated

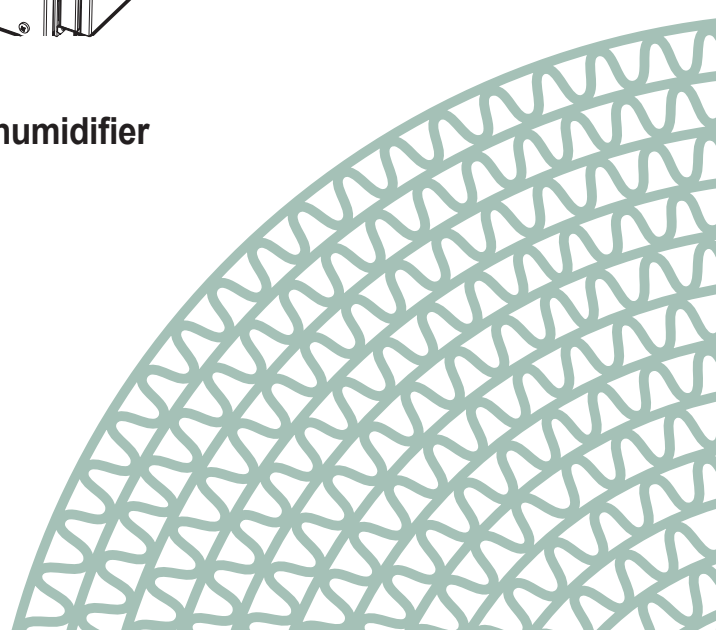

Empty page

Contents

1. Safety	7	7.2 Remote control switch	17
1.1 Aim of this document	7	7.3 Temperature safety devices	17
1.2 Emphasised text.....	7	7.4 Regeneration airflow guard	17
1.3 Intended use.....	7	8. Option & accessory	18
1.3.1 Hazardous operating conditions	7	8.1 Filter guard	18
1.3.2 Responsibilities of the operator	7	8.2 Rotation guard.....	18
1.3.3 Minimising hazards	7	8.3 Frequency converter to fans	18
1.4 Safety	7	8.4 Insulation.....	18
1.4.1 Supervision	7	8.5 Filter box.....	18
1.5 Inspection of goods	7	8.6 Energy saving.....	19
1.6 Safety advice regarding transportation.....	7	8.7 humidity controller	19
1.7 Installation	7	8.8 AUTO/ECO VENT.....	19
1.8 Electrical installation.....	8	8.9 PLC - C4	19
1.9 Commissioning	8	9. Troubleshooting	20
1.10 Operation	8	9.1 Error codes	20
1.11 Maintenance.....	8	9.2 General troubleshooting.....	20
1.12 Disposal/recycling.....	8	9.3 Capacity troubleshooting	21
2. Introduction	9	10. Maintenance	22
2.1 Type plate overview	9	10.1 Regular service interval.....	22
2.2 Model designation	9	10.2 Washing the rotor	22
2.3 Serial number structure	9	11. Technical data	23
2.4 Other unit information	9		
3. Product description	10		
3.1 Product overview.....	10		
3.2 Applications.....	10		
3.3 Principle of operation	10		
4. Installation	11		
4.1 Unit installation	11		
4.1.1 Fork lifting.....	11		
4.1.2 Transport.....	11		
4.1.3 Positioning	11		
4.2 General Duct work installation	12		
4.3 Damper installation	12		
4.4 Humidistat/electronic controller installation	12		
4.5 Electrical connection	12		
4.5.1 Power supply.....	12		
4.5.2 Earth leakage circuit breaker	13		
4.5.3 Humidistat connections.....	13		
4.5.4 0-10VDC signal	13		
4.5.5 Remote control.....	13		
4.5.6 Potential-free signals	13		
5. Operation check & adjustment	14		
5.1 Pre-operation check	14		
5.2 Start-up test and adjustment.....	14		
6. Operating	15		
6.1 Control panel	15		
6.2 Start.....	15		
6.3 Stop.....	15		
6.4 Reset buttons & switches	15		
7. Functions	16		
7.1 Dehumidification function	16		
7.1.1 Automatic or Manual	16		
7.1.2 Ventilation modes.....	16		
7.1.3 Humidistat connection	17		
7.1.4 0-10VDC connection.....	17		

Empty page

Appendix

1. Component list
2. Dimension
3. Harmful chemicals and solvents for rotors
4. CE-declaration

Electrical wiring diagram is stored in the document pocket, depending on the unit, inside or outside the electrical box. The electric diagram has a drawing number. This number should correspond to the sticker with a drawing number found inside the electric cabinet.

If applicable, separate users' manuals for components with separate controls are found in the document pocket.

Figures

FIGURE 1: Type plate.....	9
FIGURE 2: Model name	9
FIGURE 3: Serial number structure.....	9
FIGURE 4: Product overview	10
FIGURE 5: Principle of operation & rotor	10
FIGURE 6: Forks in contact with both sides of the frame.....	11
FIGURE 7: Units with handles	11
FIGURE 8: Exercise caution when lifting and transport a unit	11
FIGURE 9: Installation of wet air out duct.....	12
FIGURE 10: Humidistat positioning.....	12
FIGURE 11: Control panel	15
FIGURE 12: Illustration of automatic and manual functions.....	16
FIGURE 13: Ventilation modes for automatic control	16
FIGURE 14: Electronic filter guard	18
FIGURE 15: Manometer - mechanical filter guard	18
FIGURE 16: Manometer - mekanisk filtervakt (Magnehelic)	18
FIGURE 17: Filter box - Add-on module.....	18
FIGURE 18: EH3 T2	19
FIGURE 19: EH4.....	19
FIGURE 20: C4 PLC with 5.7" color touchscreen	19
FIGURE 21: Troubleshooting table and solution	20
FIGURE 22: General troubleshooting table and solution.....	20
FIGURE 23: Capacity troubleshooting and solution table.....	21
FIGURE 24: Service chart	22

Empty page

1 SAFETY

1.1 AIM OF THIS DOCUMENT

This document accompanies delivery and is therefore an integral part of the equipment. It describes the machine's design and configuration at the time of delivery.

In the interest of safety, please study this document before installing or operating the equipment.

Instructions relating to safety, handling, operation and maintenance must be followed.

Non-compliance can result in serious personal injury or damage to the machinery and may invalidate manufacturers' liabilities and warranties.

This document includes guidance for:

- Installers
- Operators
- Maintenance staff

Please retain this document throughout the lifetime of the equipment.

1.2 EMPHASISED TEXT



Caution! Indicates hazards that could result in damage to the equipment.



Warning! Indicates "potentially" hazardous situations that could result in damage to the equipment, serious personal injury or death.



Danger! Indicates "imminently" hazardous situations that could result in damage to the equipment, serious personal injury or death.



Attention! Indicates important information or instructions that require special attention.

1.3 INTENDED USE

This equipment is specifically designed for atmospheric air drying. It is unsuitable for any other use. For further advice please contact a DST representative.

Unless specifically stated in this manual, the following applications are prohibited:

- conditioning of gases (other than air)
- conditioning of air contaminated with chemicals or aggressive elements
- conditioning of air containing flammable or explosive elements
- in rooms or air systems having a potentially explosive atmosphere (ATEX)
- conditioning of air at elevated pressures
- air entering the rotor that has not been properly filtered with at least G4 class
- compounds in the air that will possibly deteriorate the silica gel rotor - see appendix for detailed information

1.3.1 HAZARDOUS OPERATING CONDITIONS

Operation of the system is deemed to be hazardous if it is:

- not operated inside or is not protected within a weatherproof enclosure.
- not operated within the permitted operating parameters (see technical specifications)
- operated outside the scope of 'normal' use (see intended use)

1.3.2 RESPONSIBILITIES OF THE OPERATOR

It is the responsibility of the operator of the system to ensure that all personnel engaged in the installation, operation, maintenance and service of the equipment have read and understood the relevant sections of this manual.

For your own safety, wear the appropriate personal protective equipment (PPE).

1.3.3 MINIMISING HAZARDS

To ensure that risk to personnel is minimised:

- Ensure that all activities relating to this equipment are carried out by qualified and authorised staff only.
- Identify and prevent potential safety hazards in the environment.

To ensure a failure-free operation:

- Keep this manual ready to hand with the unit.
- Use the machine as intended only.
- Only use the machine if it is fully functional.
- Check the condition of the machine before using.
- Check the machine for operational efficiency at regular intervals.
- Carry out maintenance and testing at prescribed intervals.

1.4 SAFETY

This equipment conforms to the relevant European regulations and directives and is designed and manufactured to be safe and reliable in operation.

The continued safety and reliability of the supplied equipment is entirely dependent on its correct handling, installation, operation and maintenance.

1.4.1 SUPERVISION



Warning! The appliance is not to be used by persons (including children) with reduced physical, sensory or mental capabilities, or lack of experience and knowledge, unless they have been given supervision or instruction.



Warning! Children being supervised not to play with the appliance.

1.5 INSPECTION OF GOODS

Check for transportation damage! Use this product only if you assess it as being undamaged and faultless. Any damage must be recorded by the forwarder at the time of delivery and reported to the supplier of the equipment at the earliest opportunity.

Please check the equipment carefully for damage upon receipt and after removal of all packaging.

1.6 SAFETY ADVICE REGARDING TRANSPORTATION



Warning! Only use tested and certified lifting equipment to offload and position the unit.



Warning! If a forklift is used to move the unit, please ensure the load is evenly balanced.



Warning! If lifting the unit or cassette on a pallet, ensure the unit is firmly secured to the pallet.



Warning! Evacuate and secure the danger area during lifting and positioning of the unit.

1.7 INSTALLATION



Attention! Installation, testing, commissioning and maintenance must be carried out by a qualified person or under the supervision of a qualified person. Wherever possible, all mechanical work must be carried out with the electrical supply switched off.

A qualified person (mechanical) is defined in this manual as:

- a mechanical technician or engineer qualified to service and maintain air conditioning plant and associated systems who
- has completed the appropriate health and safety training
- has read and is familiar with the contents of this manual
- is professionally competent to commission and service this type of equipment.



Caution! The air dryer is designed for internal installation. For external use it will require a weatherproof enclosure.



Caution! The air dryer must be installed on a horizontal plane.



Attention! The air ducts must be vibration-free and sizable enough to prevent pressure build-up when conveying the incoming and outgoing air from the unit.



Attention! The incoming and outgoing outlets on the machine are not designed to bear any weight from the air ducts system.



Attention! The wet air outlet duct must be insulated to prevent condensate and ice build-up in cold conditions.

1.8 ELECTRICAL INSTALLATION

! **Attention!** Wherever possible, all electrical work must be carried out with the electric supply switched off. It is recommended that electrical isolators be locked in the off position. All electrical work must be carried out by a qualified person or under the supervision of a qualified person.

A qualified person (electrician) is defined in this manual as:

- an electrical technician or engineer qualified to service and maintain air conditioning plants
- has completed the appropriate health and safety training
- has read and is familiar with the contents of this manual.

! **Danger!** If the unit control panel isolation switch is off, the incoming cable terminals may still be live!

! **Danger!** If working on the unit's isolation switch, ensure that the electrical power is isolated and locked to prevent accidental resetting.

! **Danger!** Electrical connections are to be made in accordance with local regulations.

! **Attention!** Check that the incoming electrical supply conforms to the electrical wiring diagram and the manufacturer's type plate attached to the unit.

! **Caution!** Loose terminal connections! Due to vibration during transportation it is advised that electrical terminals be checked for security and retightened where necessary. The following connecting terminals in the electrical control cabinet should be checked periodically and retightened if necessary:

- connecting terminals in the main isolator switch
- connecting terminals in main components of the heater circuits
- connecting terminals in main components of the fan circuits

Periodically as defined in this manual means:

- during installation
- during maintenance

! **Caution!** Parameters used in the electrical protection and alarm circuits must not be modified or adjusted. Factory (default) parameters are shown in the electrical wiring diagrams, technical data or parameter list.

! **Warning!** This equipment will contain high voltage electrical components!

1.9 COMMISSIONING

! **Attention!** Equipment fans can produce noise levels above 80 dB (A). Use ear protection if someone are near an operating machine for any length of time.

1.10 OPERATION

! **Caution!** Use the normal shut-down procedure in the operating chapter. If switching the unit off in an EMERGENCY, the main isolator switch or emergency stop button may be used. However, residual heat from the heater elements will remain in the unit and this can result in damage to components close to the heater.

! **Caution!** On no account should the unit be operated without air filters installed!

! **Caution!** Do not expose the unit to an ambient temperature that exceeds 50 °C/122 °F (e.g inside a plant room) for a long period of time. This may damage the internal components!

! **Caution!** Do not process air at a temperature higher than 40°C/104°F. This may damage the internal components!

1.11 MAINTENANCE

! **Caution!** Defective electrical components and defective wiring must be replaced immediately. The equipment must not be operated until the defect has been repaired and the unit has been retested.

! **Caution!** For maintenance purposes, use the normal shut-down procedure as described in the operating chapter and allow the system to cool down before attempting to access internal components.

! **Danger!** To prevent unintentional restart, ensure that the main isolator switch is off and the power is isolated before servicing internal components.

! **Attention!** Advise all operating and maintenance personnel of the automatic restart function if applicable.

! **Attention!** Pay attention to accessibility requirements for maintenance and service purposes.

! **Danger!** Only certified personnel are allowed to adjust, repair or modify the unit's refrigerant system. Contact a DST representative for any questions (Econosorb & Frigosorb only).

! **Caution!** The operation of all electrical safety devices is to be checked at commissioning and during service/maintenance. Under no circumstances are these devices to be deactivated (e.g., during adjustment or bridging).

! **Caution!** Do not expose the unit to water jets during the washing-down procedure!

! **Caution!** Do not wash the rotor!

! **Warning!** Allow the fans to come to a complete stop and the unit to be isolated from the electrical supply before removing any panels!

! **Warning!** The unit is equipped with a heating element. Do not touch the equipment whilst it is hot. Allow the unit to cool for at least **30 minutes** before any service or maintenance is performed.

! **Danger!** Manually isolate the unit from the electrical supply by turning the main isolator to "OFF" and secure it with a lock pad before conducting any type of service and maintenance work on the unit

1.12 DISPOSAL/RECYCLING

When the unit is no longer in use, dismantle the unit and recycle the components according to local regulations. Contact a DST representative if you have any questions.

2 INTRODUCTION

2.1 TYPE PLATE OVERVIEW

The manufactured unit is identified by a type plate. The details on the type plate are set out as follows:

1. Model designation
2. Serial number
3. Rotor type and date of production
4. Electrical supply information

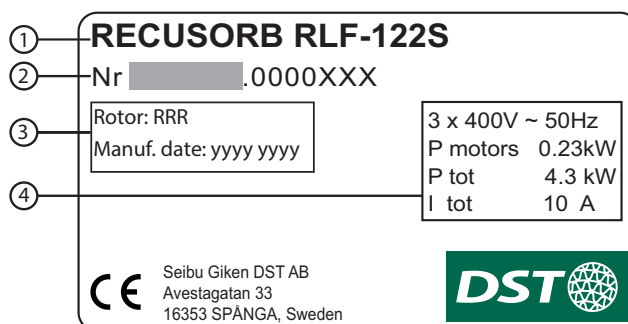

FIGURE 1: Type plate

2.2 MODEL DESIGNATION

The model designation is the name of the model and what type of regeneration the unit is fitted with.

1. Principle type
2. Model name
3. Regeneration heater type - the type of heater the unit is equipped with.*

R = Resistive (electric)	HW = Hot water
G = Gas	WW = Warm water
S = Steam	D = Diesel
	O = Oil

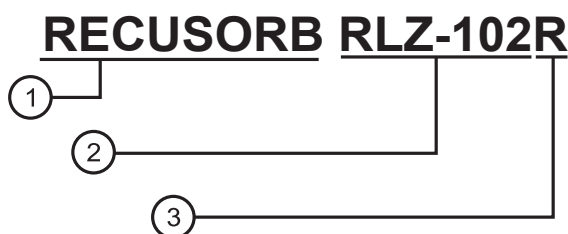

FIGURE 2: Model name

*Not applicable for single-phase unit.

2.3 SERIAL NUMBER STRUCTURE

The serial number is composed of different codes to identify the unit type. Units manufactured pre 2006 have a modified serial number structure which does not match the current structure.

1. Unit (e.g. RLZ-102)
2. Special unit (**aa**) - code to indicate a special manufactured unit
SP = Special
Note: The absence of SP indicates a standard manufactured unit; e.g. RLZ-102SP is a special manufactured unit, and RLZ-102 is a standard manufactured unit.
3. Serial number (**bbbbbbb**) - serial number of the manufactured unit
001, 002, 003, 004... n

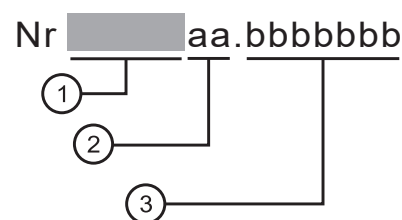

FIGURE 3: Serial number structure

2.4 OTHER UNIT INFORMATION

In the appendix, a component list details spare parts with articlenumbers as well as the electrical diagram number for the electrical box. If there is a special unit with custom-installed components that list will include a list of installed options.

3 PRODUCT DESCRIPTION

3.1 PRODUCT OVERVIEW

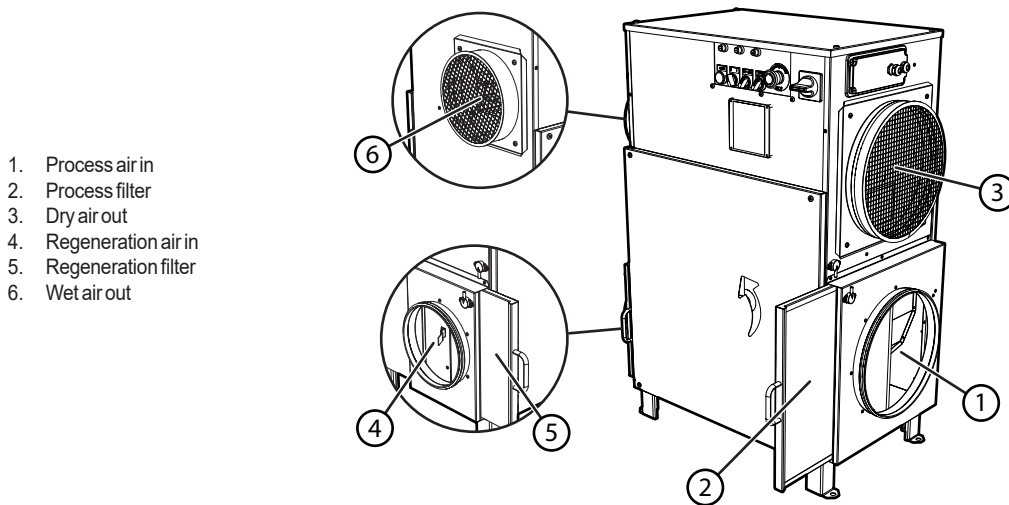

FIGURE 4: Product overview

Variation of installation and components may vary.

3.2 APPLICATIONS

DST desiccant-type dehumidifiers are normally used where dry air is essential to the various manufacturing processes used in chemical, pharmaceutical, food or confectionery industries, or where a dry environment is required for the storing and handling of moisture-sensitive products and raw materials.

The well proven air drying technology using the adsorption principle provides great flexibility in solving humidity problems. It offers the user independent humidity control, down to dew points far lower than the effective operating range of refrigeration dehumidifiers.

3.3 PRINCIPLE OF OPERATION

This is a continuous process with two air streams of different flow rates, normally having a flow ratio of approximately 3:1. The greater flow, *process air*, is dried as it passes through the dehumidifier, while the smaller flow, *regeneration air*, is used to heat the rotor material to drive the adsorbed moisture vapour from the desiccant. The moisture which is removed from the process air is transferred over to the other sector as the rotor slowly turns.

1. Wet air outlet
2. Regeneration air fan
3. Regeneration sector
4. Purge sector
5. Regeneration heater
6. Dry air outlet
7. Process air fan
8. Rotor motor
9. Process sector
10. Rotor
11. Process air inlet
12. Regeneration air in
13. Desorption process
14. Adsorption process
15. Water molecule
16. Silica gel

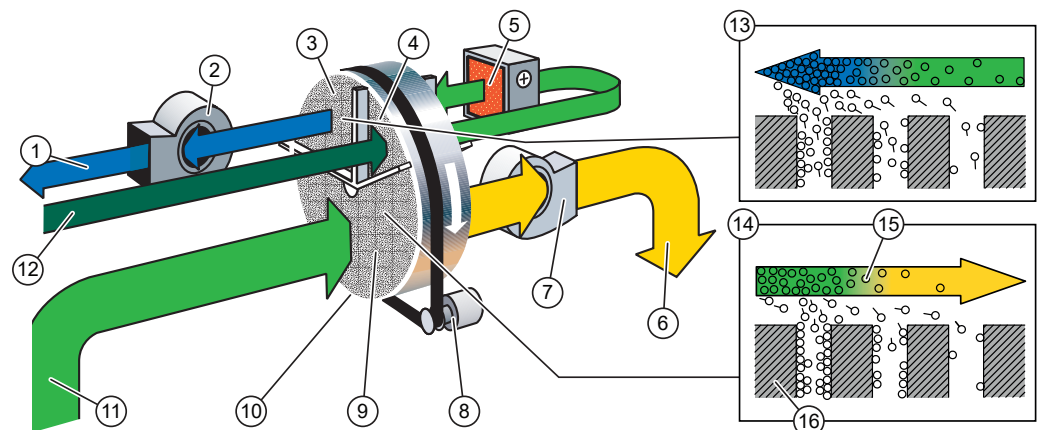

RECUSORB Light is a continuous dehumidifier with internal energy recovery and able to reach very low dew points. During regeneration, sensible heat is adsorbed by the rotor material. The rotor rotates and enters a small purge sector where part of the incoming regeneration air is pre-heated. As a result, the regeneration air is pre-heated before the air enters the regeneration heater, thus reducing the amount of energy to heat the air in the regeneration heater. Purge sector will also deadsorb some of the water molecules before the rotor enters the process sector.

Now that the excess heat in the rotor material is reduced by the purge sector. This will reactivate the rotor materials to prepare it for adsorption. When the rotor finally enters the process sector, the adsorbing starts immediately until the rotor passes over to the regeneration sector. In this sector the hot air will heat the rotor materials and deadsorbs the water molecules in to the air and exits through the wet air outlet.

FIGURE 5: Principle of operation & rotor

4 INSTALLATION

4.1 UNIT INSTALLATION

Follow the directions regarding installation of heavy and medium weight dehumidifiers.

Note: Use the installation guidelines as a reference only.

4.1.1 FORK LIFTING

The unit can be off-loaded and positioned using a fork lift by lifting between the feet of the unit, alt., on some dehumidifiers, lift the unit using the built-in handles.

- The forks must be of sufficient length to be in contact with both sides of the base frame.
- The forks should be initially positioned centrally across the middle sections of the unit but must be checked for balance prior to final lifting.
- Units equipped with handles are very heavy. Do not lift the unit single-handedly! Always ask for assistance or use lifting aid!

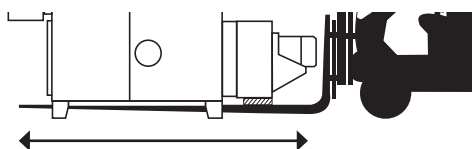

FIGURE 6: Forks in contact with both sides of the frame.

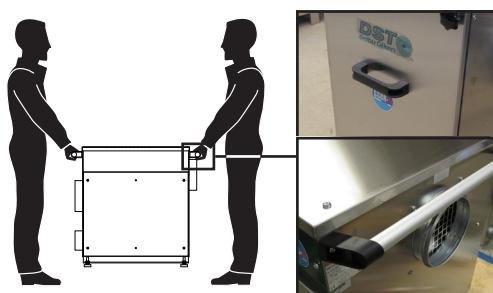

FIGURE 7: Units with handles

4.1.2 TRANSPORT

Dehumidifiers with external fans or a high centre of gravity runs the risk of tipping. Use caution when lifting and moving the dehumidifier.

Note:

- Secure any panels, doors or loose equipment.
- Keep the unit balanced at all times when moving the unit.
- See safety chapter regarding lifting safety.

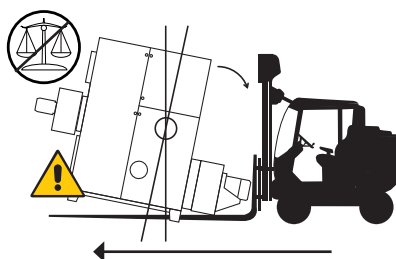

FIGURE 8: Exercise caution when lifting and transport a unit

If not balanced, the unit may run the risk of tipping during transport.

See "11 Technical data" for weight information.

4.1.3 POSITIONING

Position the machine with adequate working space around the unit to allow inspection and service. Size of unit and the position of the access panels/doors vary depending on the model. To avoid incorrect positioning, see the dimensional drawing in the appendix for service space and foot bolt-hole dimensions.

4.2 GENERAL DUCT WORK INSTALLATION

The guidelines are to assist the installers and operators to adjust the duct/dehumidifier installation. Consult a DST representative or local mechanical installation company for more information.

- Avoid recirculation from the separate airflows, direct entering and exiting airflow away from each other.
- Check if the dry air is well distributed in the dehumidified area.
- The regeneration air in and wet air out has to be connected to the outside of the dehumidified area, preferable outdoor.
- To increase the lifetime of the filter, it is recommended taking air from a higher level where dust and other particles are kept at minimum.
- Install dry air out duct/channel at a high level.
- To maximize the drying capacity, free blowing on dry air out without airflow reduction is recommended.
- Allow wet air to disperse freely when exiting the duct.
- It is recommended to insulate the wet air duct.
- The wet air duct must be installed at a sloping outwards angle, due to risk of condensation inside the duct work. The setup will also prevent condensation flowing back into the dehumidifier.
- If the duct needs to be installed higher than the wet air outlet, fix a condensate drain at the lowest point of the duct.
- Do not connect the air outlet to a ventilation system which can create pressure that will result in reverse airflow through the dehumidifier.

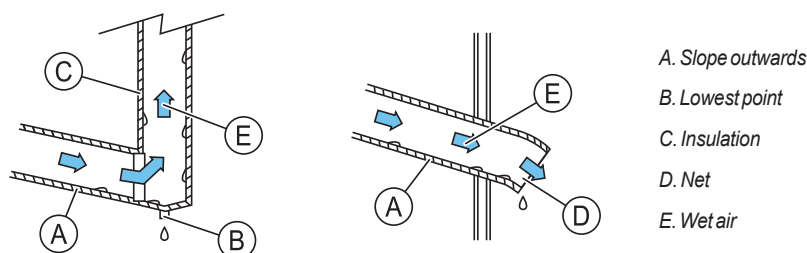

FIGURE 9: Installation of wet air out duct

4.3 DAMPER INSTALLATION

When installing dampers to adjust the airflow to nominal flow, it is recommended to place the dampers according to the table. Installing dampers on the wrong side might result in humid air mixing with dry air through infiltration between the air chambers and affect the capacity. Always maintain a higher pressure on the process air chamber than the regeneration air chamber by adjusting the dampers.

Inlet/Outlet side	Install dampers
Regeneration air inlet	•
Wet air outlet	○
Process air inlet	○
Dry air outlet	•

4.4 HUMIDISTAT/ELECTRONIC CONTROLLER INSTALLATION

Install the humidistat/electronic controller away from the dry air out path to avoid false readings.

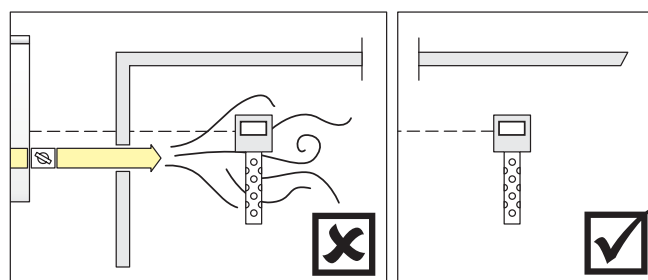

FIGURE 10: Humidistat positioning

4.5 ELECTRICAL CONNECTION

Electrical components should be connected to the supply according to the local regulations and requirements.

4.5.1 POWER SUPPLY

The incoming three-phase cable with L1, L2 and L3 are directly connected to the main switch and PE-cable connected to the earth bar.

The electrical feed must be provided on-site in accordance with the electrical diagram and local requirements.

See electrical diagram for a detailed layout and description.

4.5.2 EARTH LEAKAGE CIRCUIT BREAKER

Due to the high capacitive currents present in the AC drive, earth leakage circuit breakers may not function properly.

Note: This is only applicable if the unit is equipped with a frequency converter.

4.5.3 HUMIDISTAT CONNECTIONS

The dehumidifier has a connection for a 1-step* or 2-step** humidistat. This is optional for some models.

See electrical diagram for connections.

See "7 Functions" for more details.

* For models with no selectable heater output.

** For models with at least two selectable heater output.

4.5.4 0-10VDC SIGNAL

Units with optional connections points for an electronic humidity controller or another regulator signal is marked on the electrical diagram.

See "7 Functions" for more details.

See electrical diagram for connections.

4.5.5 REMOTE CONTROL

The unit has a connection point for a remote switch.

See electrical diagram for connections details.

See "7 Functions" for more details.

4.5.6 POTENTIAL-FREE SIGNALS

Potential free contacts are marked on the electrical diagram for connecting external indicators. These indicators are used to transmit signals to a remote centre, to indicate if unit or fans are still in operation.

Standard indicator

- Alarm indicator
- Run indicator*
- Regeneration fan indicator*
- Process fan indicator*

Optional indicators (N/A for certain units)

- Filter guard (regeneration) indicator
- Filter guard (process) indicator
- MAN/AUTO indicator

Each indicator, standard or optional, are marked on the electrical diagram to indicate whether it is a normally closed or a normally opened circuit.

* Standard indicator may differ depending on model and configuration. See electrical diagram for more information.

5 OPERATION CHECK & ADJUSTMENT

5.1 PRE-OPERATION CHECK

Danger!

The operator of the system must ensure that all personnel who are involved with installation, operation and maintenance of the machine have read the "1 Safety" sections of this manual.

1. Inspect and clean the inside of the unit from foreign objects such as rags, tools, particles of metal, and such, that may pose damage to the inside of the unit.
2. If fitted, ensure that both air balance dampers are fully open and check that the air paths of the duct work are not obstructed in any way.
3. Check that the filters are securely in place.
4. Confirm both motor overload protectors are set to Start/On position.
5. If fitted with condenser or cooler, install a water trap.
6. Confirm thermostat and overheat protection settings are in accordance with table shown "11 Technical data".
7. Confirm the incoming electrical power cable is secure and ensure that live wires are securely located in the correct terminals. Ensure the earth wire is securely located onto the earth strap or earth terminal provided.
8. Check that the rating of the electrical supply fuses is correct, see wiring diagram.

5.2 START-UP TEST AND ADJUSTMENT

1. Close and secure all access doors
2. Switch the main switch to "I" and check the supply voltage is correct.
3. Briefly start the unit and then turn it off. Promptly check if the process fan and regeneration fan is rotating in the correct direction. If incorrect check "9 Troubleshooting". See "6 Operating" on "Start" and "Stop".
4. If fitted, balance the airflows, using the dampers in the duct work or adjust the frequency of each frequency converter to obtain the required values.
5. Check the operation of fault alarms by temporarily reducing the setpoints of alarm giving thermostats and motor protectors. Do not forget to reset to the original settings according to technical data and electrical diagram.
6. Measure the current on both fans and compare with the electrical specifications printed on the fan motor casing. If the current is too high, reduce the airflow slightly by closing down on the respective balance damper.
7. If connected, check remote control operation.
8. If connected, check remote alarm function (see 5 above).
9. If connected, check humidistat/electronic humidity controller function.

6 OPERATING

6.1 CONTROL PANEL

1. [TH1] - Safety thermostat for regeneration heater - Reset switch
2. [TH2] - Control thermostat for regeneration heater
3. [TH3] - Safety thermostat for wet air outlet - Reset switch
4. [ALARM] - General alarm light
5. [OFF RESET/ON] - ON/OFF switch*
6. [AUTO/MAN] - Mode switch for AUTO or MAN
7. [HEATER] - Switch for selecting heater power**
8. [EMERGENCY] - Emergency stop button
9. [MAIN] - Main isolation switch
10. Electronic controller*** / Humidistat***

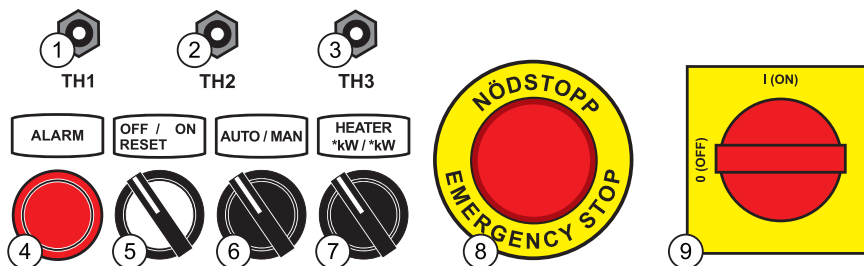

* The light indicator turns on each time the regeneration heater is active

** N/A when fitted with steam heater

*** Option

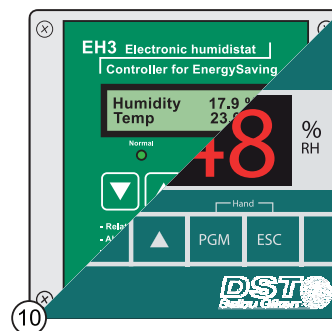

FIGURE 11: Control panel

Note: Control panel layout - for guidance only. Panel supplied may differ from that shown.

6.2 START

Start the unit.

1. Turn [MAIN]-switch to "I".
2. Turn [AUTO/MAN]-switch to "MAN" for continuous dehumidification or "AUTO" for automatic-mode with connected humidistat/regulator signal.
3. Select capacity by choose the output on [HEATER] switch.
4. Turn [0/1] to "1" and the unit starts running.

⚠ Caution!

When "Automatic restart" selected. The unit starts automatically after a power failure. It is important that all personnel involved with installation, operation, maintenance and service of the unit are made aware of this function.

6.3 STOP

Unit will shut down.

-A timed cooling down period on the regeneration fan is initiated before turned off.

1. Turn [0/1] to "0".

⚠ Caution!

Do not use the main isolator switch to turn off the unit. Always use the described stop procedure to turn off the unit.

6.4 RESET BUTTONS & SWITCHES

Fuses, overheat protections or motor protectors are found inside the electrical cabinet. The position and denotation of the devices may vary depending on the unit and configuration.

Reset is only required when a operation is halted by hardware failure or triggered a safety mechanism. See troubleshooting for more information.

See the electrical diagram for correct layout and information of the reset devices.

7 FUNCTIONS

7.1 DEHUMIDIFICATION FUNCTION

The unit is equipped with multiple modes to control the dehumidification. It allows automatic control with connected humidistat or regulator signal*, or manual override. A selectable option to set the ventilation modes during automatic mode is also possible.

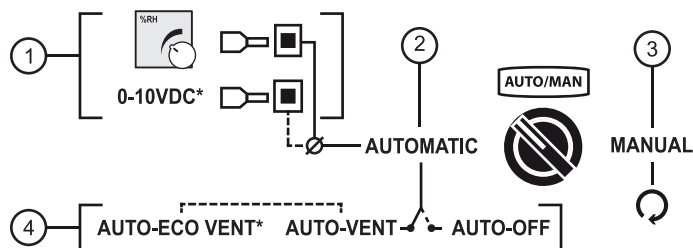

1. Connections for a humidistat or regulator signal when controlling the dehumidification.*
2. Automatic control - Dehumidification is automatically controlled using a humidistat or regulator signal
3. Manual control - Dehumidification is manually controlled using pre-set settings.
4. Selectable ventilation mode when dehumidification stops.

* Option

FIGURE 12: Illustration of automatic and manual functions

7.1.1 AUTOMATIC OR MANUAL

Main operation control is operated by selecting automatic or manual mode on the [AUTO/MAN]-switch.

AUTOMATIC [AUTO] - Dehumidification capacity is controlled automatically by a humidistat/regulator signal. A user selectable ventilation mode to save energy or to ventilate when the dehumidification need is achieved.

MANUAL [MAN] - The unit will run on selected settings until manually turned off. This mode will also prevent a humidistat or a regulator signal from shutting down the unit.

Note: Electrical heater output is selectable. Available for certain models only. See "6 Operating".

Note: AUTO-mode is only operable when a humidistat/regulator signal is connected.

Note: If the unit is fitted with Energy saving, the regeneration heater will operate on full effect in MAN-mode.

7.1.2 VENTILATION MODES

In automatic mode, the unit can operate in two different ventilation modes when the dehumidification automatically stops. The unit will automatically start dehumidify again when the humidity rises above the setpoint on the humidistat or regulator signal.

- **AUTO-VENT** is a ventilation mode that provides a constant airflow by keeping the process fan running.
- **AUTO-ECO VENT*** is a semi-ventilation mode that provides an airflow in intervals by turning the process fan ON and OFF.
- **AUTO-OFF** is not a ventilation mode, unit stops all fans and is powered down to a sleep mode.

AUTO-VENT	AUTO-ECO VENT*	AUTO-OFF	

Note: When the dehumidification stops, a timed cooling down period on the regeneration fan will be initiated to remove potential residual heat from the heaters. See cooling down timer in "11 Technical data".

Note: Factory default setting on ventilation mode varies among models. For units with PLC, mode is adjusted in the PLC. For units without PLC, change the mode by changing the terminal link wire inside the electrical cabinet. See electrical diagram for default ventilation mode on the unit.

ON OFF Timed-controlled Process fan Regeneration fan Regeneration heater Rotor motor

FIGURE 13: Ventilation modes for automatic control

The default time setting for the process fan is: **ON** (5 min) and **OFF** (55 min). Adjusting the time setting is only possible with a PLC installed, without a PLC the default time setting applies.

Note: AUTO ECO VENT is an option but it is included for DC/DR-50 and RL-60/61/71 when Energy saving 2 or 3 is selected.

* Option - Contact a DST representative for more on information on which unit can be fitted with AUTO-ECO VENT.

7.1.3 HUMIDISTAT CONNECTION

Standard units have the option to use the built-in Humidistat inputs to control the dehumidification using a 1-step or 2-step humidistat.

The built-in humidistat controls the dehumidification by reducing the regeneration heater in steps. Use a 2-step humidistat to control the heater output in three steps (maximum power, reduced power and zero power) or a 1-step humidistat for heating output in two steps (maximum power and zero power).

Mode	Two-step humidistat (Applies for electrical heater)		One-step humidistat (Applies for steam heater)	
	Humidistat inputs	Heater output	Humidistat input	Heater output
1	Humidistat step 2 (Closed) Humidistat step 1 (Closed)	Full power	Humidistat (Closed)	Full power
2	Humidistat step 2 (Opened) Humidistat step 1 (Closed)	Reduced power*	N/A	N/A
3	Humidistat step 2 (Opened) Humidistat step 1 (Opened)	Zero power	Humidistat (Opened)	Zero power

* See technical data for details on electrical heater output for reduced power.

See electrical diagram for details and connections.

7.1.4 0-10VDC CONNECTION

Note: Option

This feature replaces the standard built-in humidistat inputs when Energy saving 2 or 3* is fitted. A 0-10VDC regulator is used to control the dehumidification capacity on a precision level when the built-in Humidistat input feature is insufficient.

Electronic humidity controller	Regulator signal	Capacity output
EH3 T2/others	0...10VDC	0...100%

See electrical diagram for customer connection.

*N/A for R-51/60/61, RL-60/61/71.

See "8.6 Energy saving" for more feature description.

7.2 REMOTE CONTROL SWITCH

Connections for an external power switch is available as standard. The remote power switch allows the user to shut down or turn on the unit from another location.

Note: The external power switch overrides the manual and automatic mode and must be restored to start the unit.

See electrical diagram for connections.

7.3 TEMPERATURE SAFETY DEVICES

Integral "fail-safe" temperature devices will protect the unit from damage caused by component failure, incorrect settings or abnormal operating conditions.

Type	Thermostat function	Thermostat description	Thermostat location	Reset is required
TH1	Safety thermostat	An overheat protection device that stops the unit if the temperature exceeds the set limit	Inside the regeneration heater compartment	Yes
TH2	Control thermostat	A device that controls the set regeneration temperature	Inside the regeneration heater compartment	No
TH3	Safety thermostat	An overheat protection device that stops the unit if the temperature exceeds the set limit	In the proximity of wet air outlet	Yes

Temperature device types used will vary between models fitted with a PLC and those without a PLC. See below.

Units with PLC	Units without PLC
Two shielded electronic sensors, programmed on PLC as TH2 and TH3. Reset TH3 on PLC. Mechanical thermostat TH1* – reset on thermostat.	Only mechanical thermostats installed - TH1, TH2 and TH3 Mechanical thermostat TH1* and TH3 - reset on thermostats.

*N/A when fitted with coils.

See "11 Technical data" for default temperature settings.

See electrical diagram for the location of the thermostats.

! Attention!

If TH1 or TH3 are tripped, an automatic safe shut down procedure will be initiated. On units fitted with a PLC an alarm code will be displayed. On units without a PLC an alarm is indicated by a red light on the control panel. The shut down procedure includes a timed cooling down period and, if fitted, closing of associated valve actuators.

! Attention!

Should TH1 trip, it will automatically disable the regeneration heater circuit breakers. These must be reset before attempting to restart the unit.

7.4 REGENERATION AIRFLOW GUARD

The fail-safe device automatically turns off the the regeneration heater from overheating due to insufficient regeneration airflow. The pressure switch is adjustable but it is not recommended. See "11 Technical data" for default setting.

The airflow guard is a warning only and will not shut down the unit or turn on a alarm light. If there is a potential reduced capacity, see "9.3 Capacity troubleshooting" to locate the issue.

8 OPTION & ACCESSORY

8.1 FILTER GUARD

Filter guard is a pressure indicator which tells the condition of the filter. Different options are available for purchase and comes in different varieties, such as a mechanical (differential U-tube manometer) or an electronic filter guard.

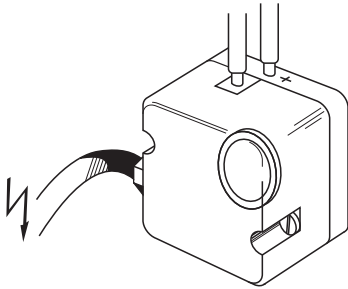

FIGURE 14: Electronic filter guard

If the differential pressure increases beyond the recommended value, the filter needs to be replaced as soon as possible. This is indicated by warning light or a message on the PLC.

See "11 Technical data" for recommended pressure for each filter type.

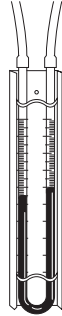

FIGURE 15: Manometer - mechanical filter guard
Note: Only applicable when filter box is selected. See "8.5 Filter box".

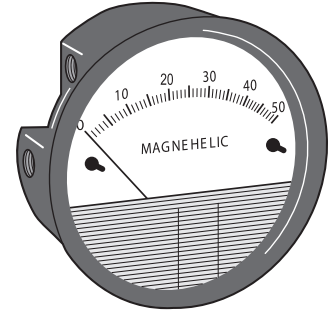

FIGURE 16: Manometer - mekanisk filtervakt (Magnehelic)

8.2 ROTATION GUARD

A safe guard feature that stops the unit from overheating in case of a sudden stop in the rotor rotation. The rotation guard will stop the unit and turn on an alarm indicator or display an error message on the PLC.

Note: Included in Energy saving 2 and 3.

8.3 FREQUENCY CONVERTER TO FANS

The frequency converter is used to set the desired airflow without dampers and reduce start-up current.

See electrical diagram for more information and location of the frequency converter.

Note: Due to the high capacitive currents present in the AC drive, earth current leakage breaker may not function properly.

8.4 INSULATION

19mm (foamed rubber) insulation can be added along the inside of the process air compartment to prevent possible condensation on the inside and outside surface of the unit.

Note: Only applicable when filter box is selected, "8.5 Filter box".

8.5 FILTER BOX

Add-on component to allow sub options to be installed and to improve process airflow.

Available sub-options for filter box:

- 19 mm insulation
- Filter guard
- F7 Filter

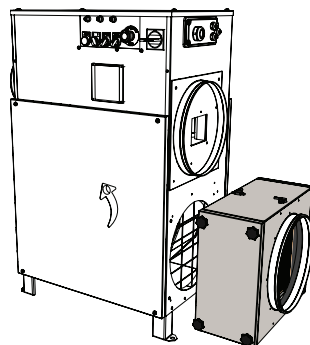

FIGURE 17: Filter box - Add-on module

8.6 ENERGY SAVING

To save energy, the unit can be fitted with different “Energy saving” features.

Energy saving 1: The reactivation heater power output is regulated in two steps. Using a EH3 T2 or EH4 to adjust the drying capacity between High, Low & Off, as required to maintain the humidity (or dew point) between two programmable setpoints.

Energy saving 2: The reactivation heater power is fully regulated between zero and full capacity using either binary (multi-step) or linear (triac or actuator) control. Using a humidity controller EH3 T2 + PLC C2 or an external control signal (BMS + PLC C2), the drying capacity is finely adjusted to accurately maintain the required setpoint (humidity or dew point).

Contact a DST representative to view the energy saving option for each specific unit as options across the products range may vary.

8.7 HUMIDITY CONTROLLER

Control the dehumidification process using the advanced electronic humidity controller EH3 T2 or the simpler electronic humidistat EH4. The devices can be built in the electrical box next to the control panel or loose device for on-site installation.

See “8.6 Energy saving” for more information on what features they can be installed on.

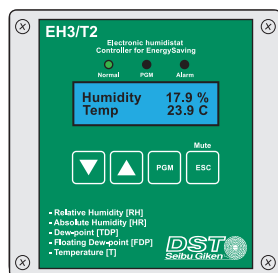

FIGURE 18: EH3 T2

Electronic humidity controller with multiple settings and advanced control for dehumidification,

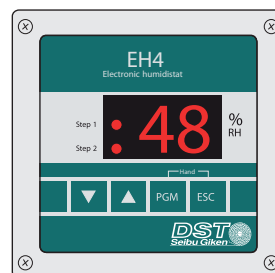

FIGURE 19: EH4

2-step humidistat for less demanding dehumidification control.

Note: Data sheet and user’s manual is available separately.

8.8 AUTO/ECO VENT

AUTO-ECO VENT is a semi-ventilation mode that provides an airflow in intervals by turning the process fan ON and OFF.

The default time setting for the process fan is: **ON** (5 min) and **OFF** (55 min). Adjusting the time setting is only possible with a PLC installed, without a PLC the default time setting applies.

Note: Included in Energy saving 2.

8.9 PLC - C4

The C4 is a touchscreen enabled PLC with multiple I/O and is installed with custom software that allows advanced dehumidification for a specific need.

Add-on modules allows, e.g. remote control using modbus, ethernet using TCP/IP modbus or modem control.

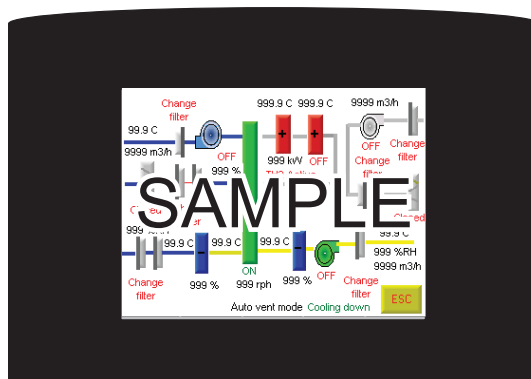

FIGURE 20: C4 PLC with 5.7" color touchscreen

Consult a DST representative for more information.

9 TROUBLESHOOTING

9.1 ERROR CODES

The dehumidifier will automatically shut down if an error is detected. During shut down, a timed cooling down period on the regeneration fan is initiated before turned off. See below for error codes.

CODE	EXPLANATION	CAUSE	SOLUTION
If the unit stops and the ALARM-light is lit.	Process fan overloaded. Regeneration fan overloaded.	Excessive airflow. Short-circuit or fan malfunction.	Check fan. Check setpoint of F1/F2 or Q1/Q2. Reset F1/Q1 or F2/Q2 – check and adjust airflow. Have a qualified electrical technician to investigate.
	Regeneration air thermostat TH1 has tripped. Regeneration heater overloaded. Note: Not applicable when fitted with steam.	TH1 setting incorrect. TH1 defective (fail safe). Incorrect shut down. Insufficient regeneration airflow. Excessive regeneration heater power. Regeneration heater malfunction.	Check TH1 setting. Check correct operation of TH1. Reset TH1 - reset F3 - F5. Check regeneration airflow and fan operation. Check TH2 setting. Check and replace heater.
	Overload in the transformer.	Short-circuit or transformer malfunction.	Check transformer.
	Wet air thermostat tripped (TH3).	TH3 setting incorrect. Excessive regeneration airflow. Excessive regeneration heater power . Incorrect or intermittent rotor rotation. Insufficient system moisture load.	Check TH3 setting. Check and adjust regeneration airflow. Check TH2 setting. Check rotor drive system. Check process airflow and fan operation. Check process inlet moisture content. Check RH controller setpoint/output control signal.
	Rotation guard sensor has not detected movement (KA13).	Rotor drive system failure. Sensor failure or incorrect clearance.	Check drive motor & transmission (correct belt tension). Check clearance gap between sensor and rotor marker. Turn the [0/1]-switch to "0"-position and main switch to "0/OFF"-position to restore.
Frequency converter alarm. Note: Option	Frequency converter internal alarm activated	Refer to converter manual for fault code explanation.	
EMERGENCY STOP BUTTON is lit.	Operation terminated.	Emergency button activated. [0/1]-switch is active (if fitted with auto restart).	Pull the emergency button to restore. Turn the [0/1]-switch to "0"-position to restore.
The unit is running and the ALARM Δ P-light is lit. Note: Applicable for RL-61/71 only.	Internal pressure balance is not optimal.	The negative pressure on the regeneration air chamber is insufficient. See more information on "4.3 Damper installation".	Throttle the damper on regeneration air in or dry air out until ALARM Δ P-light is turned off. Reduce the pressure fall by changing the process inlet filter more frequently. Check the airflow guard. Check the airflow guard setting (recommended is 30Pa). Note: Top panel must be mounted during testing to avoid triggering the ALARM Δ P.

FIGURE 21: Troubleshooting table and solution

9.2 GENERAL TROUBLESHOOTING

Check for following if the unit will not start-up.

PROBLEM	CAUSE	SOLUTION
Unit will not start. None of the light indicators are on.	No power to unit. No power to control circuit. The emergency stop button is active.	Confirm electric supply and check local isolator is on. Check remote control is set to 'On/Run' position. Check all circuit breakers are set to 'Start/On' position. Pull the emergency stop button and then turn the operating switch to "0".
The ALARM-light is on but the unit will not start.	Alarm circuit is preventing start-up.	Check TH1 & TH3 thermostats are set. Check all circuit breakers are set to 'Start/On' position. Check fan motor overloads are set to 'Start/On' position.
The dehumidifier is turned on but does not appear to be operating.	A circuit is preventing operation.	Operation can be checked by lowering control setpoint or switching to 'manual' operation. Check remote control is set to 'On/Run' position and if the cable is undamaged. Confirm electric supply and check local isolator is on.

FIGURE 22: General troubleshooting table and solution

9.3 CAPACITY TROUBLESHOOTING

The dehumidifier performance can be roughly checked by feeling the temperature of the uninsulated duct work near the unit.

PROBLEM	OBSERVATION	SOLUTION
The dehumidifier does not maintain required condition or achieve expected performance, despite being operated at full power.	Dry air outlet duct is warm and wet air outlet duct is very warm (normal operation).	Check actual moisture load against calculated design moisture load. Check controller setpoint/output signal. Check airflows are set as specified, adjust as necessary. Check air filters. Check dehumidifier casing and duct work for air leakage. Check rotor alignment and condition of radial and peripheral rotor seals.
	Both outlet air ducts are cold (no alarm).	Check regeneration airflow and fan operation. Check regeneration heater operation. Check controller setpoint/output signal. Check TH2 setting.
	Dry air outlet duct is cold, wet air outlet duct is hot (no alarm).	Check rotor rotation. Check process airflow and fan operation.
	The regeneration heater light indicator is not turning on or flashing.	Check regeneration airflow - Remove blockages or open dampers on the regeneration airflow. Check pressure switch and setting. Note: N/A for R-51/60.
	None or low regeneration airflow is detected.	Check regeneration fan. Check TH2 thermostat and setting. Check TRIAC and cooling fan.
Measured airflows are lower than specified.	Fan is not rotating in direction indicated by arrow on fan motor casing. The incoming phase supply is incorrect.	Isolate mains electrical power supply to the unit. Change over two of the three incoming phase supply wires. Re-check fan rotation.

FIGURE 23: Capacity troubleshooting and solution table

10 MAINTENANCE

10.1 REGULAR SERVICE INTERVAL

Service time	Run time in hours (x1000)	0	4'	8'	12'	16'	20'	24'	28'	32'	36'	40'	44'	48'
	Calendar time in months	0	6	12	18	24	30	36	42	48	54	60	66	72
Inspect filter - replace if necessary		X	X	X	X	X	X	X	X	X	X	X	X	X
Clean and inspect the unit				X		X		X		X		X		X
Inspect fan - replace if necessary				X		X		X		X		X		X
Inspect features and functionality		X		X		X		X		X		X		X
Inspect electric, feature, cables and electrical components - replace if worn or damaged				X		X		X		X		X		X
Inspect access panels, locks and panel seals - replace if necessary				X				X				X		
Inspect duct and duct connections		X				X				X				X
Inspect heater and cooler				X		X		X		X		X		X
Inspect humidistat/humidity sensor - replace if necessary				X		X		X		X		X		X
Inspect rotor motor - replace if necessary				X		X		X		X		X		X
Inspect radial & peripheral seals - replace if worn or damaged				X		X		X		X		X		X
Check operation of geared drive motor, drive pulley, belt/chain, rotor - adjust as necessary				X		X		X		X		X		X
Inspect rotor for contamination or damage - clean/repair (contact DST)		X		X		X		X		X		X		X
Inspect condenser*				X		X		X		X		X		X
Inspect evaporator*				X		X		X		X		X		X
Inspect compressor*				X		X		X		X		X		X
Inspect cooling system*		X		X		X		X		X		X		X

Safety feature check (if fitted)														
Function test on thermostats			X		X		X					X		X
Function test on the freeze alarm	X		X		X		X		X		X		X	X
Function test on rotation guard alarm, check and adjust sensor clearance	X		X				X					X		
Function test on damper, actuator and valves	X		X		X		X		X		X		X	X
Function test on post-cooling function	X		X		X		X		X		X		X	X

FIGURE 24: Service chart

This is a general service chart and the time interval vary depending on the operating condition. Some options listed here may not be installed or available for this specific unit.

Danger!

All personnel involved with installation, operation and maintenance of this unit should familiarise themselves with the safety section of this manual.

*Applicable for Frigosorb and Econosorb.

10.2 WASHING THE ROTOR

The D-MAX rotor has a distinct advantage over other types of desiccant rotors in that dust and grease can be washed out of the material without the need for reimpregnation after treatment. In all normal applications however it must be emphasised that washing of the rotor should be considered as a last resort having alleviated all other possible defects first.

Caution!

Please contact a DST-representative before attempting to wash the rotor!

11 TECHNICAL DATA

RL-60 RL-60L

Capacity		
Capacity [kg/h]	¹	4 5
Nominal dry air flow [m ³ /h]	²	850 1000
External static pressure dry air [Pa]	²	300 100
Nominal wet air flow [m ³ /h]	²	180 250
External static pressure wet air [Pa]	²	250 150
Regeneration heater - Electric		
Heater power [kW]		5.4 7.5
Number of electric heater steps		2 2
Heating power in steps [kW]		1/2 - 3 1/2 - 4,5 2/2 - 5,4 2/2 - 7,5
Heating power with linear control [kW]	⁴	0-5.4 0-7.5
Humidistat 2 opens and reduce the power to [kW]		3 4.5
Total power - Electrical		
Total motor power [kW]		0.67 0.8
Total power [kW]		6.07 8.3
Other electrical information		
Supply fuse 3x400V/50Hz [A]		16 16
Humidistat connection		230VAC 230VAC
Humidistat supply current [A]	⁵	< 1 < 1
Temperature setpoint settings		
Overheat protection TH1 [°C]		190 190
Thermostat TH2 [°C]		180 180
Overheat protection TH3 [°C]		80 80
Temperature limits		
Max. process air inlet temperature [°C]		40 40
Max. operating temperature [°C]		50 50
Min. operating temperature [°C]		-20 -20
Other technical data		
Air filter class (regeneration/process)		G4/G4 G4/G4
Filter change at pressure (G4/F7) [Pa]	⁶	200/250 200/250
Airflow guard - Regeneration [Pa]		30 30
Noise level [dB(A)]	³	- -
Regeneration air fan delay [min]		10 10
Weight [kg]		68 68

¹ Valid for inlet conditions 20 °C/ 60%RH (equal 1.2 kg/m³).

² If no data is stated here the volume flow above is given at free blowing airflow.

³ Unit connected to uninsulated ducts. Nominal airflows.

⁴ Applies for dehumidifiers with installed optional feature.

⁵ The current provided by the humidistat connection. Only use humidistats that are capable of this load current.

⁶ (EN779 = ISO16890) G4 = Coarse 60%, M5 = ePM10 60%, F7 = ePM1 60%, F9 = ePM1 85%

The content of in this document may be subject to change without prior notice. For questions and comments regarding the content in this document, please send it to

Seibu Giken DST AB, ATT: Documentation, Avestagatan 33, 163 53 SPÅNGA, SWEDEN.

E-mail: info@dst-sg.com, subject: Documentation.

Component list RL-60

Description	Type, Drwg No etc	60	60L	Qty.	Art No	Notes
Rotor unit						
Rotor	DMR-550H05	<input checked="" type="checkbox"/>	<input checked="" type="checkbox"/>	1	108676	
Rotor mantle seal	DX1175-13mm	<input checked="" type="checkbox"/>	<input checked="" type="checkbox"/>	0,15m	102851	
Rotormotor	80.547.0 6 rpm 230V 50Hz 0,033A 7,2kW	<input checked="" type="checkbox"/>	<input checked="" type="checkbox"/>	1	109059	
Belpulley	30 5M 09 axel 8	<input checked="" type="checkbox"/>	<input checked="" type="checkbox"/>	1	100642	
Belt	1870 5M 09	<input checked="" type="checkbox"/>	<input checked="" type="checkbox"/>	1	104654	
Fans						
Proc fan motor	0,37 kW 3x230/400V 50Hz	<input checked="" type="checkbox"/>	<input type="checkbox"/>	1	112731	
Proc fan motor	0.55 kW 3x230/400V 50Hz	<input type="checkbox"/>	<input checked="" type="checkbox"/>	1	112732	
Impeller	160x62 Ø14	<input checked="" type="checkbox"/>	<input checked="" type="checkbox"/>	1	112747	
Inlet cone	ED1/160	<input checked="" type="checkbox"/>	<input checked="" type="checkbox"/>	1	112703	
Reg fan motor	0.25 kW 3x230/400V 50Hz	<input checked="" type="checkbox"/>	<input checked="" type="checkbox"/>	1	112730	
Impeller	146x62 Ø11	<input checked="" type="checkbox"/>	<input checked="" type="checkbox"/>	1	112749	
Inlet cone	ED1/146	<input checked="" type="checkbox"/>	<input checked="" type="checkbox"/>	1	112704	
Filter						
Filter	414x440x16mm G4	<input checked="" type="checkbox"/>	<input checked="" type="checkbox"/>	1	109974	Process
Filter	149x332mm G4	<input checked="" type="checkbox"/>	<input checked="" type="checkbox"/>	1	109973	Regeneration
Regeneration heater - Resistive heater						
Reg.heater	5,4 kW 3x230/400V	<input checked="" type="checkbox"/>	<input type="checkbox"/>	1	108989	
Reg.heater	7,5 kW 3x230/400V	<input type="checkbox"/>	<input checked="" type="checkbox"/>	1	108990	
Other						
Electric box	Dwg: 10600-05	<input checked="" type="checkbox"/>	<input type="checkbox"/>	1	109000	
Electric box	Dwg: 10720-05	<input type="checkbox"/>	<input checked="" type="checkbox"/>	1	109000	

Harmful chemicals and solvents for rotors

SEIBU GIKEN CO.,LTD.

Reduced performance and/or rotor degradation is possible when adsorping the following substances.

	Substance	Note	Chemical formula	Cause
1	Oil vapor		N/A	Clogs the micro pores on the silica gel/zeolite.
2	Ammonia	2ppm and above, prolonged exposure	NH ₃	Degrades the silica gel/zeolite.
3	Amine		RNH ₂	
4	Hydrogen fluoride		HF	Corrodes the silica gel/zeolite.
5	Sodium hydroxide	High concentration	NaOH	Dissolves the silica gel/zeolite.
6	Potassium hydrate	High concentration	KOH	Clogs the micro pores on the silica gel/zeolite.
7	Lithium chloride		LiCl	
8	Sodium chloride		NaCl	
9	Potassium chloride		KCl	
10	Calcium chloride		CaCl ₂	
11	Magnesium chloride		MgCl ₂	
12	Aluminum chloride		AlCl ₃	
13	Seawater		N/A	
14	Strong acid	pH=3 and below	N/A	Deteriorates the honeycomb's physical structure.
15	Plasticizer		N/A	Clogs the micro pores on the silica gel/zeolite.
16	Nitrogen oxides	High concentration, excessive exposure	NO _x	Deteriorates the honeycomb's physical structure.
17	Sulfur oxides	High concentration, excessive exposure	SO _x	
18	High-temperature steam	Exposod to vapor of 100 and above.	N/A	Cracks occurs on the honyecomb.
19	Heat solubility dust		N/A	Dust covers the silica gel/zeolite surface.

There is no guarantee that other substances beyond this list may reduce the dehumidification performance or damage the silica gel/zeolite.

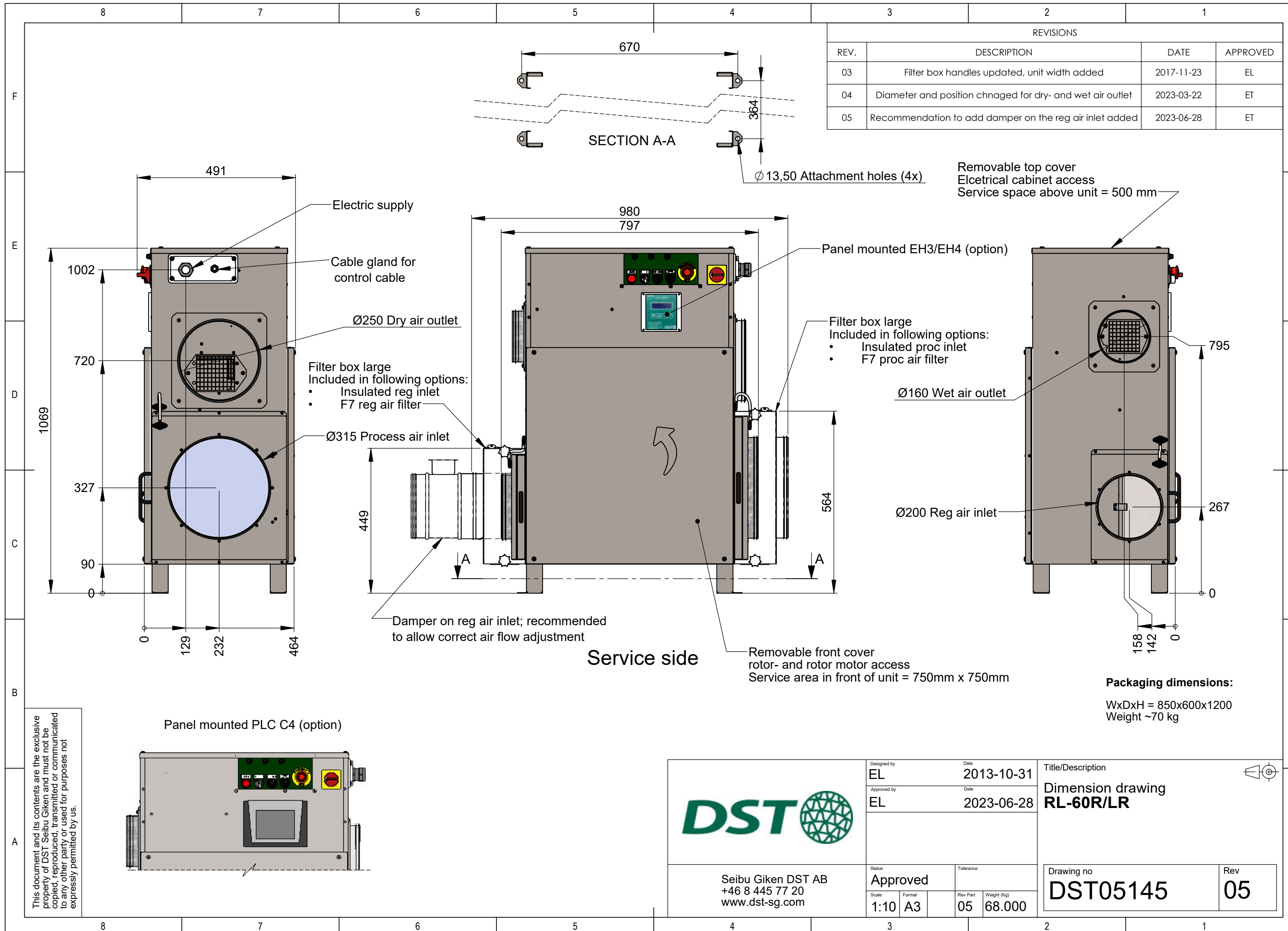

REVISIONS			
REV.	DESCRIPTION	DATE	APPROVED
03	Filter box handles updated, unit width added	2017-11-23	EL
04	Diameter and position chnged for dry- and wet air outlet	2023-03-22	ET
05	Recommendation to add damper on the reg air inlet added	2023-06-28	ET

This document and its contents are the exclusive property of DST Seibu Giken and must not be copied, reproduced, transmitted or communicated to any other party or used for purposes not expressly permitted by us.



Seibu Giken DST AB
 +46 8 445 77 20
 www.dst-sg.com

Designed by EL	Date 2013-10-31
Approved by EL	Date 2023-06-28
Status Approved	Tolerance
Scale 1:10	Format A3
Rev Part 05	Weight (Kg) 68.000

Title/Description Dimension drawing RL-60R/LR	
Drawing no DST05145	Rev 05

Declaration of conformity and incorporation for CE & UKCA

As of 2022, the latest declaration of conformity for fully assembled machinery and declaration of incorporation of partly assembled machinery for CE and UKCA are available for downloads.

Scan the follow QR-code to access all types of certificates via a phone or tablet.



If unable to scan the QR-code, visit DST website at:

<https://www.dst-sg.com/certificates/>

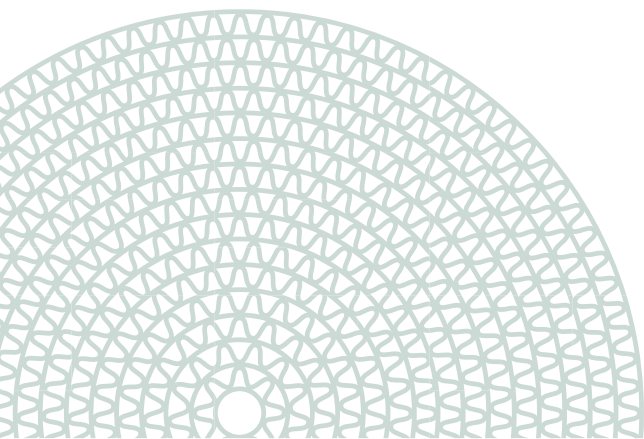

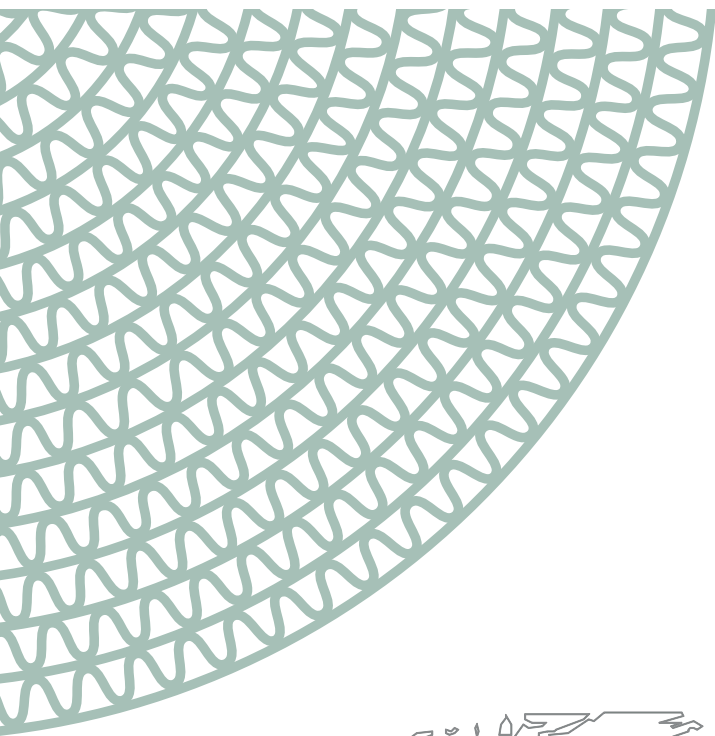

Seibu Giken DST AB
Avestagatan 33 | 163 53 Spånga, Sweden

Phone: +46 8 445 77 20 | Fax: +46 8 445 77 39
info@dst-sg.com | www.dst-sg.com



Seibu Giken DST is certified
according to ISO 9001