

Wet air out
 Purge air inlet
 Process air inlet

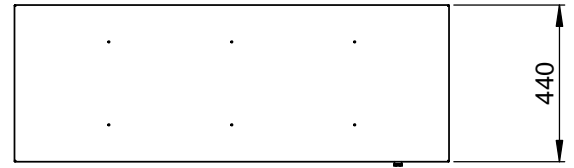

This document and its contents are the exclusive property of DST Seibu Giken and must not be copied, reproduced, transmitted or communicated to any other party or used for purposes not expressly permitted by us.

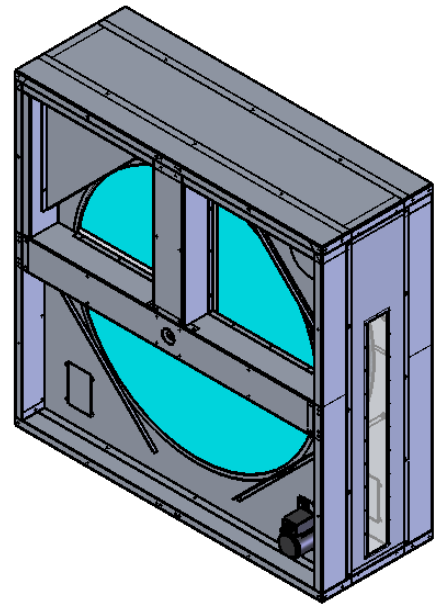
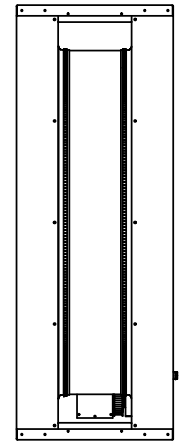
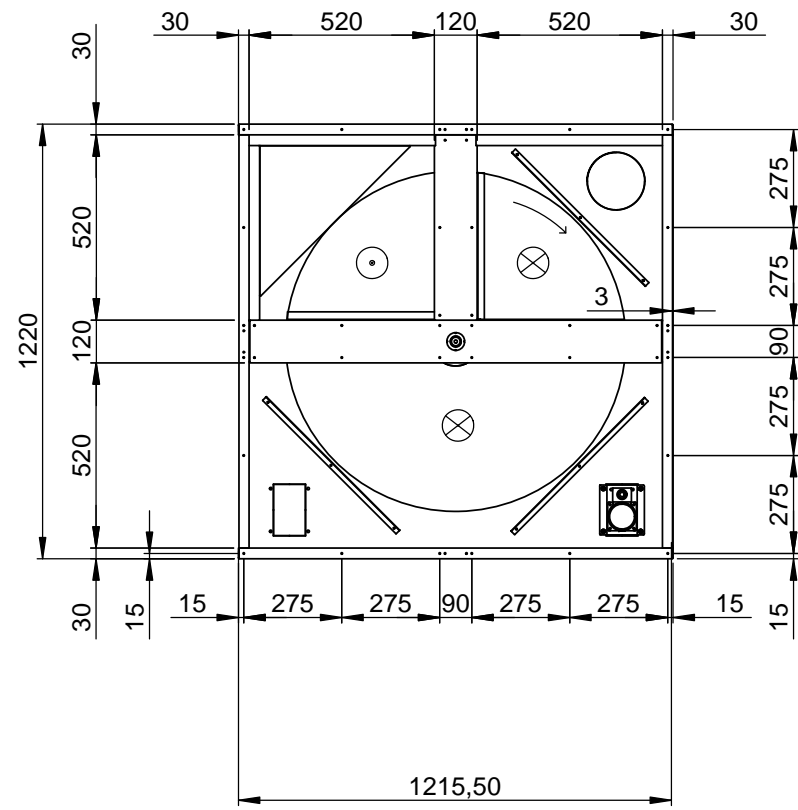
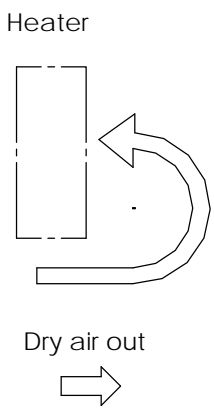
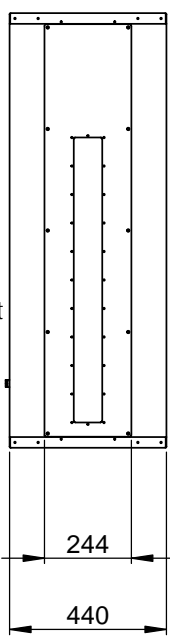

Seibu Giken DST AB
 +46 8 445 77 20
 www.dst-sg.com

Designed by	Catarina S	Date	2011-05-04
Drawn by	Catarina S	Date	2011-05-09
Approved by	-	Date	-
Material	-	Thickness	t=
Status	Construction	Tolerance	ISO 2768-1m
Scale	1:15	Format	A3
Sheets/Sheet	1/1	Rev Part	00+
Weight (Kg)	1222.460		

Title/Description	
Installationsritning RU-102 60 15 25	
Installation drawing	
Drawing no	Rev
DST00771	00+

