

# Dehumidifer RECUSORB RZ -71/ 81/101/102 ICE

Dehumidifying capacity  
at 20°C / 60%RH

**13.5 - 54 kg/h**

Dry air flow

**4500 - 12000 m<sup>3</sup>/h**



- *Developed for ice-rinks*
- *Washable rotor*
- *No desiccant carry-over*
- *Built-in heat recovery*
- *Low dry air temperature*
- *Long lifetime*

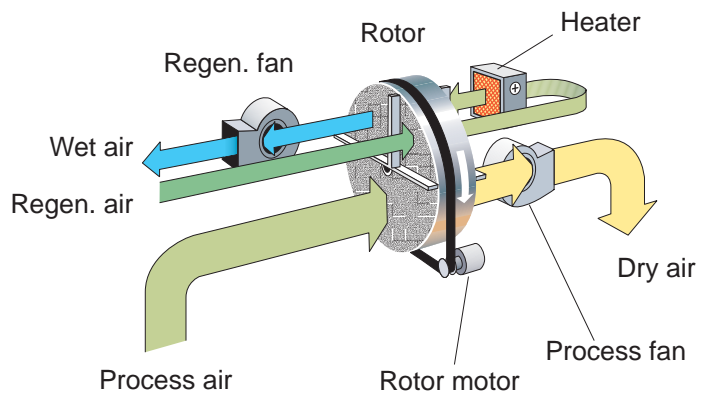

*Contains the SSCR rotor -  
one step ahead in  
adsorption technology*

*The high number of channels  
means that moisture is adsorbed  
with extra efficiency!*

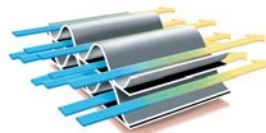

Dehumidifier model ICE	RZ-71	RZ-81	RZ-101	RZ-102
Dry air flow *	4500 m <sup>3</sup> /h	4500 m <sup>3</sup> /h	9000 m <sup>3</sup> /h	12000 m <sup>3</sup> /h
Static pressure at disposal	300 Pa	300 Pa	300 Pa	300 Pa
Wet air flow *	780 m <sup>3</sup> /h	1000 m <sup>3</sup> /h	1800 m <sup>3</sup> /h	2500 m <sup>3</sup> /h
Static pressure at disposal	200 Pa	200 Pa	200 Pa	200 Pa
Heater power **	16 kW	24 kW	40 kW	63 kW
Maximum electric consumption	20 kW	28 kW	47 kW	74 kW
Supply fuse 3x 230/400V 50Hz	63 / 35 A	80 / 50 A	125 / 80 A	250 / 125 A
Weight	290 kg	304 kg	390 kg	513 kg

\* Volume flow for density 1.20 kg/m<sup>3</sup>.

\*\* Available with electric heater, steam heater or gas heater.

kg/h		10°C			15°C			20°C		
		30% RH	50% RH	70% RH	30% RH	50% RH	70% RH	30%RH	50% RH	60% RH
RZ-71 ICE	*	8.0	10.5	12.0	9.5	12.0	13.5	11.0	13.0	13.5
	**	6.0	9.0	11.5	7.5	10.5	13.0	8.5	12.0	13.0
RZ-81 ICE	*	9.5	14.0	17.0	12.0	16.5	19.0	14.5	18.5	19.5
	**	8.5	13.0	16.0	10.5	15.0	18.5	12.5	17.0	19.0
RZ-101 ICE	*	16.5	23.5	28.0	21.0	27.5	31.0	24.5	30.0	32.0
	**	14.0	21.5	27.0	17.5	25.0	30.5	20.5	28.0	31.0
RZ-102 ICE	*	27.0	40.5	48.0	35.0	47.0	53.0	42.0	51.0	54.0
	**	24.5	37.0	46.0	31.0	43.5	52.0	36.5	48.0	52.5
* Regeneration and process air at same condition										
** Regeneration air in at 25°C 12 g/kg.										

**Dimensions for  
RZ- 71 81 101 102 [mm]**  
 A 1907 1907 2245 2200  
 B 950 950 1340 1250  
 C 1550 1550 1850 1940

**Dimensions for  
RZ- 71 81 101 102 [mm]**  
 D 400 400 500 630  
 F 200 200 315 400  
 G 160 160 250 315

**Dimensions for □ E**  
 RZ-71: 630 x 236  
 RZ-81: 630 x 236  
 RZ-101: 786 x 306  
 RZ-102: 880 x 338

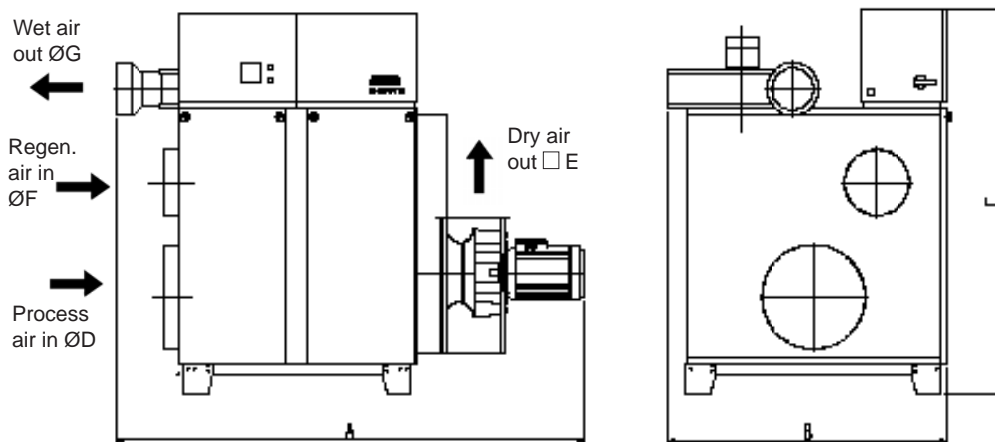

Subject to change without notice.  
 Download installation drawing at [www.dst-sg.com](http://www.dst-sg.com)

**Seibu Giken DST AB**  
 Avestag. 33, S-163 53 Spånga, Sweden  
[www.dst-sg.com](http://www.dst-sg.com) E-mail: [info@dst-sg.com](mailto:info@dst-sg.com)  
 tel: +46-8 4457720; fax: +46-8 4457739

**Representative:**