

# Dehumidifier Recusorb **RZ-71/81/101/102**



*Dehumidifying capacity at 20°C / 60%RH*  
**14 - 50 kg/h**

*Dry air flow*  
**2500 - 7000 m<sup>3</sup>/h**

- Washable rotor
- No desiccant carry-over
- Ideal for storage applications
- Built-in heat recovery
- Low dry air temperature
- Long lifetime

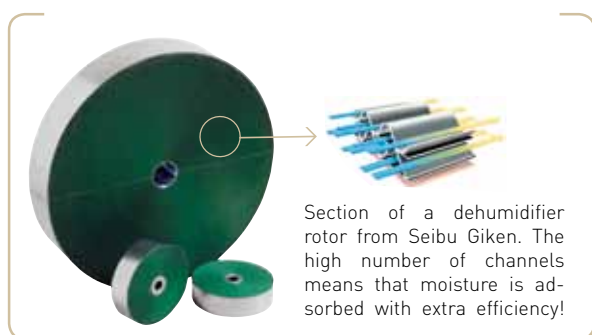

TECHNICAL DATA

Dehumidifier model	RZ-71	RZ-81	RZ-101	RZ-102
Nominal capacity <sup>1</sup> (kg/h)	14	19	30	50
Dry air flow <sup>2</sup> (m <sup>3</sup> /h)	2500	2800	4500	7000
Static pressure at disposal (Pa)	400	400	400	400
Wet air flow <sup>2</sup> (m <sup>3</sup> /h)	780	1000	1800	2500
Static pressure at disposal (Pa)	200	200	200	200
Heater power <sup>3</sup> (kW)	16	24	40	63
Maximum electric consumption (kW)	19	27	44	72
Supply fuse 3x 230/400V 50Hz (A)	63 / 35	80 / 50	125 / 80	250 /
Weight (kg)	280	294	380	503

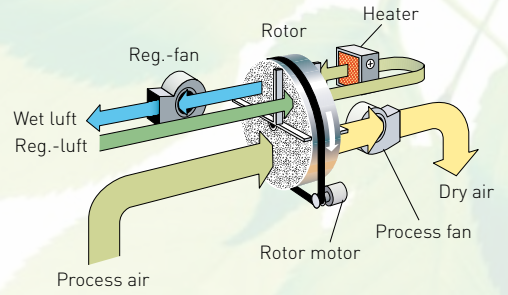

- <sup>1</sup> Valid for inlet conditions 20°C/ 60%RH. For other inlet conditions the capacity can be calculated by using the correction factor from the diagram shown below.
- <sup>2</sup> Volume flow for density 1.20 kg/m<sup>3</sup>.
- <sup>3</sup> Available with electric heater, steam heater or gas heater

CORRECTION DIAGRAM

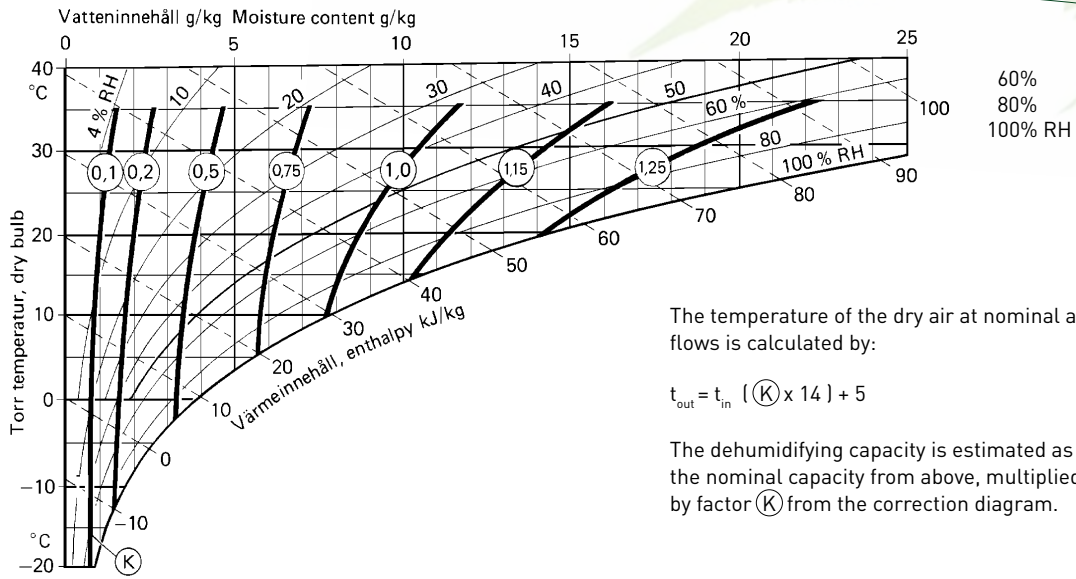

DIMENSIONS

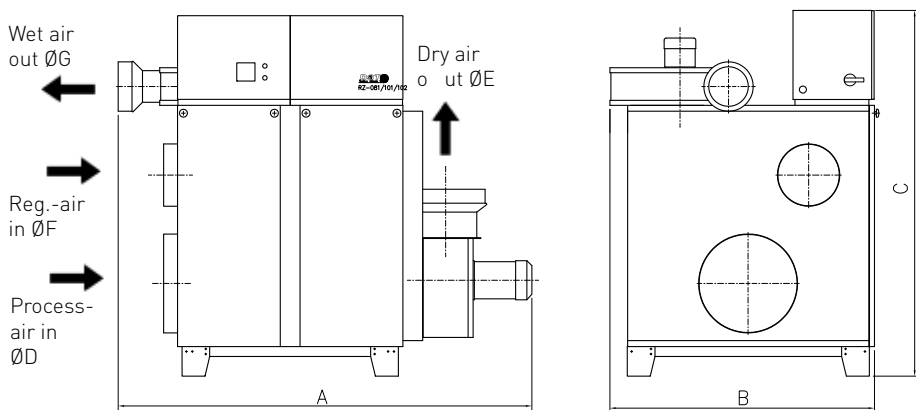

Dimensions for RZ units [mm]				
RZ-	71	81	101	102
A	1800	1800	2100	2200
B	950	950	1340	1250
C	1500	1550	1850	1940
D	400	400	500	630
E	250	250	400	500
F	200	200	315	400
G	160	160	250	315

Subject to change without notice. Download installation drawing at [www.dst-sg.com](http://www.dst-sg.com)

DST Seibu Giken AB

Avestagatan 33 | SE-163 53 Spånga, Sverige

Tel +46 8 445 77 20 | Fax +46 8 445 77 39

[www.dst-sg.com](http://www.dst-sg.com) | [info@dst-sg.com](mailto:info@dst-sg.com)

Representatives worldwide in over 40 countries, see [www.dst-sg.com](http://www.dst-sg.com)